



Model	ICR18650/20P	Spec. No.	RD-EVE ICR18650/20P-S60-LF	Version No.	B
-------	--------------	-----------	----------------------------	-------------	---

PRODUCT SPECIFICATION

Lithium-ion rechargeable cell for power tools

Model: EVE-ICR18650/20P

Draft	Checked	Confirmed	Approved
Walker	Spencer	Yeqi	David

Customer signature
Company name:
Approved by:
Signature date:

April, 2019

EVE Energy Co., Ltd.



Model	ICR18650/20P	Spec. No.	RD-EVE ICR18650/20P-S60-LF	Version No.	B
-------	--------------	-----------	----------------------------	-------------	---

Revision history

Revision No.	Date	Page	Item	Description	Author
A	2018-12-14	/	/	First Edition	Walker
B	2019-4-16	1. Page 1 2. Page 1 3. Page 4	1. Max. Continuous Discharge; 2. Cell Dimension 3. Status of the cell as of ex-factory	Parameter Optimization	Walker

Model	ICR18650/20P	Spec. No.	RD-EVE ICR18650/20P-S60-LF	Version No.	B
-------	--------------	-----------	----------------------------	-------------	---

1.0. Scope

This product specification has been prepared to specify the rechargeable lithium-ion cell to be supplied to customer by EVE Energy CO., LTD.

2.0. Description and Model

- 2.1 Description Lithium-ion rechargeable cell
- 2.2 Model name EVE-ICR18650/20P

3.0. Nominal Specifications

Item	Specification
3.1 Nominal Discharge Capacity	2000mAh Charge: 1A, 4.20V, CCCV 100mA cut-off Discharge: 0.4A, 2.50V DC cut-off
3.2 Nominal Voltage	3.60V
3.3 Standard Charge	CCCV, 1A, 4.20 ± 0.05V, 100mA cut-off
3.4 Rapid Charge	CCCV, 4A, 4.20 ± 0.05V, 100mA cut-off
3.5 Standard Discharge	DC, 0.4A, 2.50V cut-off
3.6 Max. Continuous Discharge	DC, 30A, 2.50V cut-off (cut-off temperature 80°C)
3.7 Charge/Discharge Voltage Range	4.20~2.50V
3.8 Cell Weight	45.0g Max
3.9 Cell Dimension	Height: 65.00 ± 0.15mm Diameter: 18.35 ± 0.10mm
3.10 Operation Temperature	Ambient Temperature: Charge: 0 to 45°C Discharge: -20 to 60°C
	Cell Surface Cut-off Temperature: Charge: 0 to 50°C (recommended recharge release <45°C) Discharge: -20 to 80°C (recommended re-discharge release <60°C)

Model	ICR18650/20P	Spec. No.	RD-EVE ICR18650/20P-S60-LF	Version No.	B
3.11 Storage Temperature (At Shipping SOC)		1 year	0~25°C		
		3 months	0~45°C		
		1 month	0~60°C		

4.0. Outline Dimensions

See the attachment (Fig. 1).

5.0. Appearance

There shall be no such defects as rust, discoloration, leakage which may adversely affect commercial value of the cell.

6.0. Standard Test Condition

6.1 Environment Condition

Unless otherwise specified, all tests stated in this specification are conducted at temperature $25 \pm 2^\circ\text{C}$ and humidity under 65% RH.

6.2 Measuring Equipment

(1) Amp-meter and volt-meter

The amp-meter and volt-meter should have an accuracy of the grade 0.5mA and 0.5mV or higher.

(2) Slide caliper

The slide caliper should have 0.01mm scale.

(3) Impedance meter

The impedance meter with AC 1kHz should be used.

7.0. Characteristics

7.1 Standard Charge

Standard Charge means charging the cell CCCV with charge current 1A(0.5C), constant voltage 4.20V and 100mA cut-off in CV mode at 25°C for capacity.

7.2 Rapid Charge

Rapid Charge means charging the cell CCCV with charge current 4A (2C), constant voltage 4.20V and 100mA cut-off in CV mode at 25°C.

7.3 Standard Discharge Capacity

The Standard Discharge Capacity is the initial discharge capacity of the cell, which is measured with discharge current of 0.4A(0.2C) with 2.50V cut-off at 25°C within 1 hour after the standard charge.

Model	ICR18650/20P	Spec. No.	RD-EVE ICR18650/20P-S60-LF	Version No.	B
-------	--------------	-----------	----------------------------	-------------	---

Discharge Capacity \geq 1900mAh
(Referring IEC61960 standard)

7.4 Initial Internal Impedance

Initial Internal Impedance is measured at AC 1kHz at shipping SOC.

Initial Internal Impedance \leq 18m Ω

7.5 Discharge Rate Capabilities

Discharge capacity is measured with the various currents in the following table and 2.50V cut-off after the standard charge.

Item	Discharge Condition				
Current	0.4A	2A	10A	15A	20A
Relative Capacity	\geq 100%	\geq 95%	100%	\geq 95%	\geq 95%

Note: Relative capacity is divided by the discharge capacity of 10A.

7.6 Temperature dependence of discharge capacity

Capacity comparison at each temperature, measured after 3 hours storage at the test environment with discharge constant current 10A and 2.50V cut-off after the standard charge at 25°C.

Item	Discharge temperature				
Temperature	-20°C	-10°C	0°C	25°C	60°C
Relative Capacity	\geq 60%	\geq 75%	\geq 80%	100%	\geq 100%

Note: Relative capacity is divided by the 10A discharge capacity at 25°C.

7.7 Cycle Life

7.7.1 20A Cycle Life

Charge: rapid charge(4A, 4.20V, 100mA cut-off).

Discharge:20A discharge, cut-off temperature 80°C(2.50V cut-off).

Rest time: 10min after charge and 30min after discharge.

Capacity after 300cycles.

Capacity \geq 1200mAh (60% of the nominal capacity at 25 \pm 2°C)

Model	ICR18650/20P	Spec. No.	RD-EVE ICR18650/20P-S60-LF	Version No.	B
-------	--------------	-----------	----------------------------	-------------	---

7.8 Storage Characteristics

Initial Capacity: Standard discharge capacity.

Retention Capacity: The standard discharge capacity after fully standard charged storage at condition in the following table.

Recovery Capacity: The standard discharge capacity of three times cycles after fully standard charged storage at condition in the following table.

Retention Ratio= Retention Capacity/ Initial Capacity*100%

Recovery Ratio= Recovery Capacity/ Initial Capacity*100%

Item	Retention Ratio	Recovery Ratio
60°C30Days	≥80%	≥90%

7.9 Status of the cell as of ex-factory

The cell should be shipped in 3.550V to 3.600V charging voltage range.

8.0. Mechanical Characteristics

8.1 Drop test

Test method: Each fully charged cell is dropped three times from a height of 1.0m onto a concrete floor at 20±5°C. The cells are dropped so as to obtain impacts in random orientations. After the test, the cells shall be put on rest for a minimum one hour and then a visual inspection shall be performed.

Criteria: No fire, no explosion.

Drop test shall be performed with the IEC62133 standard.

8.2 Vibration test

Test method: For X and Y axis with cylindrical cell 7Hz→200Hz→7Hz for 15min, repetition 12times totally 3hours, the acceleration 1g during 7 to 18Hz, then amplitude 1.6mm and maximum 8g up to 200Hz. Tests are to be conducted at 20±5°C.

Criteria: No fire, no explosion, no leakage, with less than 10% of OCV drop.

Vibration test shall be performed with the UN38.3 standard.

9.0. Safety

9.1 Overcharge test

Test method: Fully standard discharged cell is charged with 8.2A to 7.5V, until charging time up to 7h.

Model	ICR18650/20P	Spec. No.	RD-EVE ICR18650/20P-S60-LF	Version No.	B
-------	--------------	-----------	----------------------------	-------------	---

Criteria: No fire, no explosion.

9.2 External Short-circuit test

Test method: Fully standard charged cell is to be short-circuited by connecting the positive and negative terminals of the cell with a circuit load having a resistance load of $80 \pm 20 \text{m}\Omega$. Until the test time is lasting to 10min.

Criteria: No fire, no explosion.

External short-circuit test shall be performed with the UL1642 standard.

9.3 Forced Discharge test

Test method: A discharged cell is subjected to a reverse charge at $2A(1C)$ for 90min at $20 \pm 5^\circ\text{C}$.

Criteria: No fire, no explosion.

Forced discharge test shall be performed with the IEC62133 standard.

9.4 Heating test

Test method: To heat up the standard charged cell at heating rate 5°C per minute up to 130°C and keep the cell in oven for 10 minutes.

Criteria: No fire, no explosion.

Heating test shall be performed with the UL1642 standard.

9.5 Low Pressure test

Test method: Fully standard charged cell is to be stored at a pressure of 11.6 kPa or less for at least six hours at ambient temperature.

Criteria: No fire, no explosion and no leakage with less than 10% of OCV drop.

Low pressure test shall be performed with the UN38.3 standard.

10.0. Warranty

The warranty period of cells are made according to business contract. However, even though the problem occurs within this period, EVE won't replace a new cell for free as long as the problem is not due to the failure of EVE manufacturing process or is due to customer's abuse or misuse.

EVE will not be responsible for trouble occurred by handling outside of the precautions in instructions.

EVE will not be responsible for trouble occurred by matching electric circuit, cell pack and charger.

Model	ICR18650/20P	Spec. No.	RD-EVE ICR18650/20P-S60-LF	Version No.	B
-------	--------------	-----------	----------------------------	-------------	---

EVE will be exempt from warranty any defect cells during assembling after acceptance.

11.0. Precautions and Safety Instructions

Lithium-ion rechargeable cells subject to abusive conditions can cause damage to the cell and/or personal injury. Please read and observe the standard cell precautions below before using utilization.

Note 1. The customer is required to contact EVE in advance, if the customer needs other applications or operating conditions than those described in this document.

Note 2. EVE will take no responsibility for any accident when the cell is used under other conditions than those described in this document.

Note 3. For the sake of safety assurance, please discuss the equipment design, its system and protection circuit of Lithium-ion cell with EVE in advance. And consult about the high rate current, rapid charge and special application in the same way.

12.0. Guide for the use of Lithium-ion cells

12.1 General

This chapter has been prepared to describe the appropriate cautions and prohibitions, which the customer should take or employ when the customer uses and handles the lithium ion cell to be manufactured and supplied by EVE Energy CO., LTD., in order to obtain optimal performance and safety.

12.2 Charging

12.2.1 Charging current

Charging current shall be less than maximum charge current specified in the specification.

12.2.2 Charging voltage

Charging shall be done by voltage less than that specified in the specification.

12.2.3 Charging temperature

The cell shall be charged within a range of specified temperatures in the specification.

12.2.4 Reverse charging

The cell shall be connected, confirming that its poles are correctly aligned. Inverse charging shall be strictly prohibited. If the cell is connected improperly, it may be damaged.

12.3 Discharging

Model	ICR18650/20P	Spec. No.	RD-EVE ICR18650/20P-S60-LF	Version No.	B
-------	--------------	-----------	----------------------------	-------------	---

12.3.1 Discharging current

The cell shall be discharged continuously at less than maximum discharging current specified in the specification. In case of the higher discharging current should be set, it shall be discussed with EVE.

12.3.2 Discharging temperature

The cell shall be discharged within a range of temperatures specified in the specification. Otherwise, it may cause loss of performance characteristics.

12.3.3 Over-discharging

The system should equip with a device to prevent further discharging exceeding discharging cut-off voltage specified in the specification.

Over-discharging may cause loss of performance characteristics of cell. Over-discharging may occur by self-discharging if the cell is left for a very long time without any use.

The charger should equip with a device to detect voltage of cell box and to determine recharging procedures.

12.4 Storage

12.4.1 Storage conditions

The cell should be stored within a range of temperatures specified in the specification. Otherwise, it may cause loss of performance characteristics, leakage and/or rust.

12.4.2 Long term storage

The cell should be used within a short period after charging because long-term storage may cause loss of capacity by self-discharging. If long-term storage is necessary, the cell should be stored at lower voltage within a range specified in the specification, because storage with higher voltage may cause more loss of performance characteristics.

12.5 Cycle life

12.5.1 The cell can be charged & discharged repeatedly up to times with a certain level of capacity specified in specification.

12.5.2 Cycle life may be determined by conditions of charging, discharging, operating temperature and/or storage.

12.6 Design of system

12.6.1 Connection between the cell and the battery

Model	ICR18650/20P	Spec. No.	RD-EVE ICR18650/20P-S60-LF	Version No.	B
-------	--------------	-----------	----------------------------	-------------	---

The cell should not be soldered directly with other cells. Namely, the cell should be welded with leads on its terminal and then be soldered with wire or leads to solder. Otherwise, it may cause damage of component, such as separator and insulator, by heat generation.

12.6.2 Positioning the battery in the system

The battery should be positioned as possible as far from heat sources and high temperature components. Otherwise, it may cause loss of characteristics. The recommended spacing between the cells is more than 1mm.

12.6.3 Mechanical shock protection of the battery

The battery should be equipped with appropriate shock absorbers in the pack in order to minimize shock, which can damage the cells. Otherwise, it may cause shape distortion, leakage, heat generation and/or rupture and/or open circuit.

12.6.4 Short-circuit protection of the cell

The cell equips with an insulating sleeve to protect short-circuit which may occur during transportation, battery assembly and/or system operation. If the cell sleeve is damaged by some cause such as outside impact, it may cause short-circuit with some wiring inside the battery.

12.6.5 Connection between the battery and charger/system

The battery should be designed to be connected only to the specified charger and system. A reverse connection of the battery, even in the specified system, should be avoided by employing special battery design such as a special terminal.

12.6.6 Pack design

The current consumption of the battery pack should be under 10uA at sleep mode.

The system should be equipped with a device to monitor each voltage of cell block to avoid cell imbalance which can cause damage to the cells.

The battery pack or system should have warning system such as over temperature, over voltage, over current, and so on.

12.7 Battery pack assembly

12.7.1 Prohibition of usage of damaged cell

The cell should be inspected visually before battery assembly.

The cell should not be used if sleeve-damage, can-distortion and/or electrolyte-smell is detected.

Model	ICR18650/20P	Spec. No.	RD-EVE ICR18650/20P-S60-LF	Version No.	B
-------	--------------	-----------	----------------------------	-------------	---

12.7.2 Terminals handling

Excessive force on the negative terminal should be avoided when external strip terminal is welded.

12.7.3 Transportation

If the cell is necessary to be transported to such as the battery manufacturer, careful precautions should be taken to avoid damage of cell.

12.8 Others

12.8.1 Disassembly

The cell should not be dismantled from the battery pack.

Internal short-circuit caused by disassembly may lead to heat generation and/or venting.

When the electrolyte with fresh water and seek medical advice.

12.8.2 Short-circuiting

Short-circuit results in very high current which leads to heat generation.

An appropriate circuitry should be employed to protect accidental short-circuiting.

12.8.3 Incineration

Incinerating and disposing of the cell in fire are strictly prohibited, because it may cause rupture and explosion.

12.8.4 Immersion

Soaking the cell in water is strictly prohibited, because it may cause corrosion and leakage of components to be damaged to functions.

12.8.5 Mixing use

Different types of cell, or same types but different cell manufacturer shall not be used, which may lead to cell imbalance, cell rupture or damage to system due to the different characteristics of cell.

12.8.6 Battery exchange

Although the cell contains no environmentally hazardous component, such as lead or cadmium, the battery shall be disposed according to the local regulations when it is disposed.

The cell should be disposed with a discharged state to avoid heat generation by an inadvertent short-circuit.

12.8.7 Caution

Model	ICR18650/20P	Spec. No.	RD-EVE ICR18650/20P-S60-LF	Version No.	B
-------	--------------	-----------	----------------------------	-------------	---

The battery used in this device may present a risk of fire or chemical burn if mistreated.

Do not disassemble, expose to heat above 100°C or incinerate it.

Do not expose the cell to extreme heat or flame.

Do not short circuit, over-charge or over-discharge the cell.

Do not subject the cell to strong mechanical shocks.

Do not immerse the cell in water or sea water, or get it wet.

Do not reverse the polarity of the cell for any reason.

Do not disassemble or modify the cell.

Do not handle or store with metallic like necklaces, coins or hairpins, etc.

Do not use the cell with conspicuous damage or deformation.

Do not connect cell to the plug socket or car-cigarette-plug.

Do not make the direct soldering onto a cell.

Do not touch a leaked cell directly.

Do not use Lithium-ion cell in mixture.

Do not use or leave the cell under the blazing sun (or in heated car by sunshine).

Keep cell away from children.

Do not drive a nail into the cell, strike it by hammer or tread it.

Replace battery with those of EVE only.

13.0. Others

13.1 Storage for a long time

If the cell is Stored for a long time (3 months or more), it is strongly recommended that the cell is performed one cycle, the voltage of the cell is recommended from 3.50V to 3.80V, the environment should be low-temperature (normally 0~25°C), dry and no corrosive gas.

13.2 Others

Any matters not involved in this specifications, should be conferred with the both parties.

14.0. Consultation

14.1 Address: EVE Energy Co., Ltd.-EVE Industrial Park on No.38,Huifeng7th Road, Zhongkai Hi-Tech Zone, Huizhou.

14.2 Tel No.: 86-752-2630809

14.3 Fax No.: 86-752-2606033



Model	ICR18650/20P	Spec. No.	RD-EVE ICR18650/20P-S60-LF	Version No.	B
-------	--------------	-----------	----------------------------	-------------	---

14.4 Website: [Http://www.evebattery.com.cn](http://www.evebattery.com.cn)

Model	ICR18650/20P	Spec. No.	RD-EVE ICR18650/20P-S60-LF	Version No.	B
-------	--------------	-----------	----------------------------	-------------	---

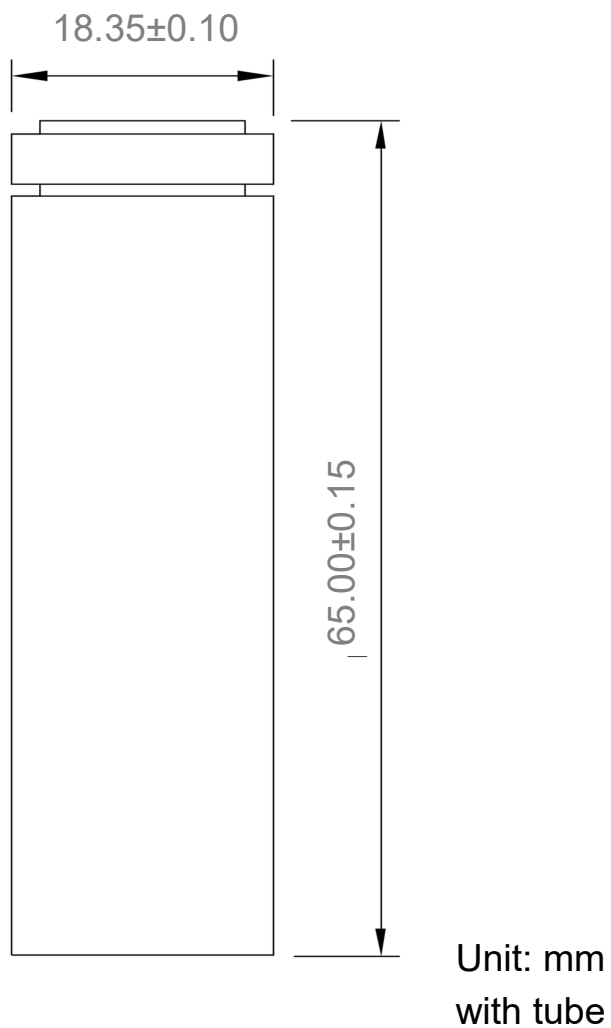
Attachment:**Fig 1:****Fig. 1. Outline Dimensions of ICR18650/20P**

Model	ICR18650/20P	Spec. No.	RD-EVE ICR18650/20P-S60-LF	Version No.	B
-------	--------------	-----------	----------------------------	-------------	---

Attachment:

Fig 2:

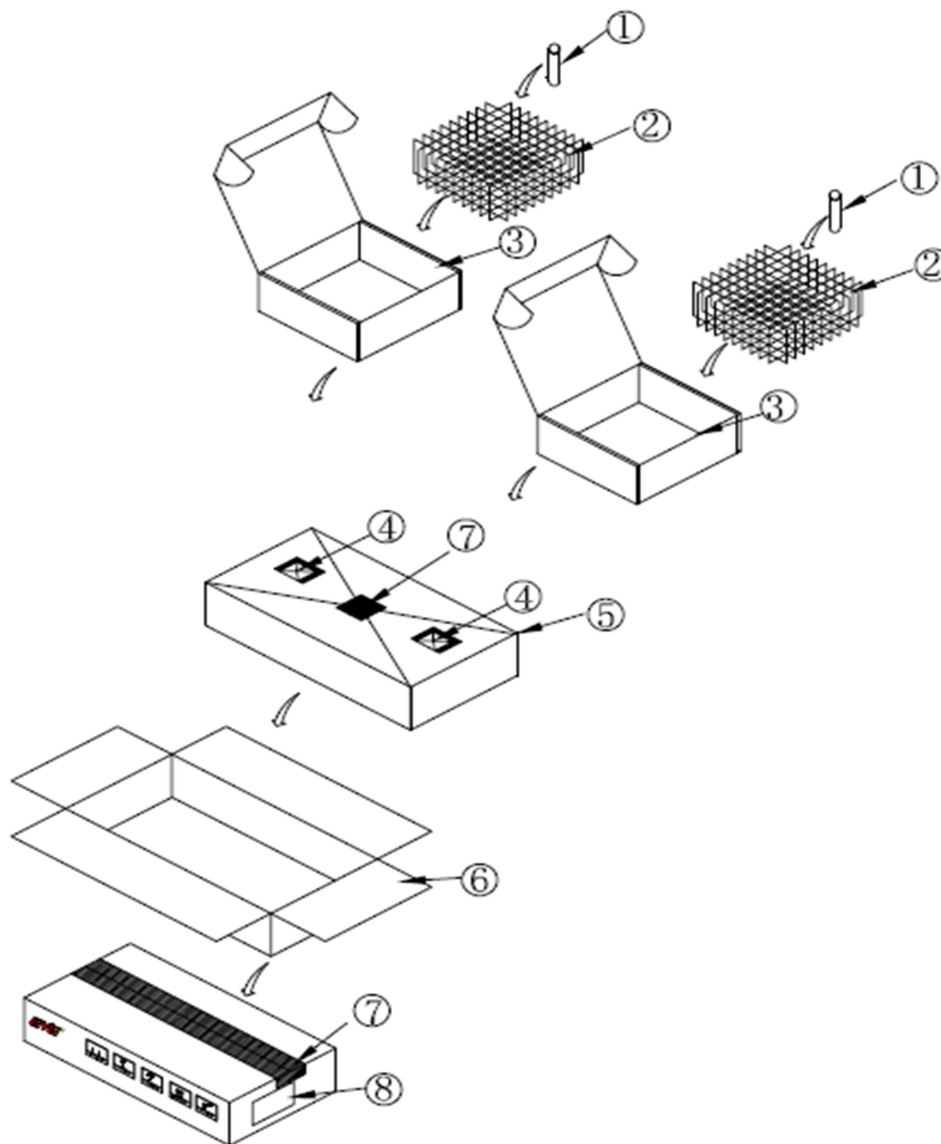

NO	PART NAME	MATERIAL	MATERIAL DIM	QTY
1	ICR18650	ICR18650/20P	φ18.45, H65.15	200
2	PACKING GUIDE	MANILA	L188XW188XH67	36
3	PACKING CASE IN	K3K Single Wall	L210XW200XH75	2
4	SILICAGEL	Si	L47XW57 5g	2
5	PE BAG	PE	L430XH340XT0.04	1
6	PACKING CASE OUT	K5K Single Wall	L415XW215XH85	1
7	TAPE	PE	W50XT0.05	1
8	LABEL	ART PAPER	L70XW100	1

Fig. 2.Package drawing

Model	ICR18650/20P	Spec. No.	RD-EVE ICR18650/20P-S60-LF	Version No.	B
-------	--------------	-----------	----------------------------	-------------	---

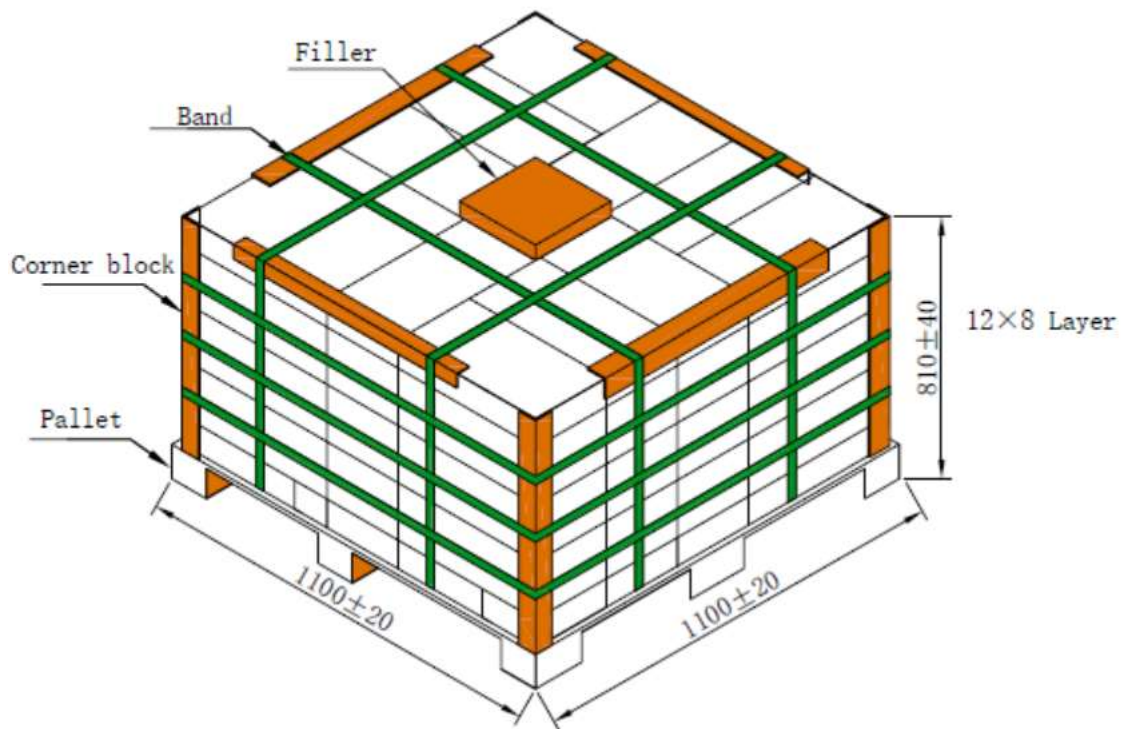
Attachment:**Fig 3:****Fig. 3. Sea/land transportation package**

Model	ICR18650/20P	Spec. No.	RD-EVE ICR18650/20P-S60-LF	Version No.	B
-------	--------------	-----------	----------------------------	-------------	---

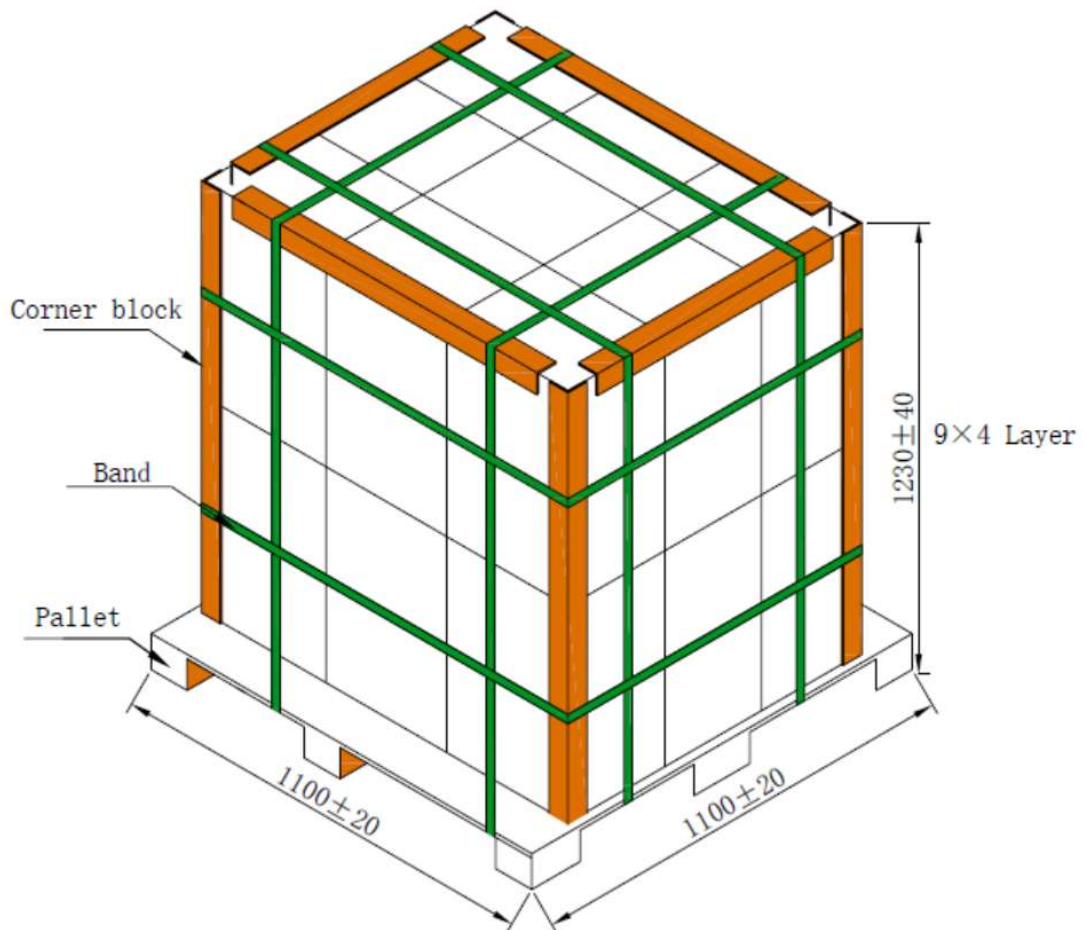
Attachment:**Fig 4:****Fig. 4. Air transportation package**